

1. Technical description.

The MP1E (AWZ612) relay module is to be used in low-voltage installations. It is intended for controlling and status indication in e.g. alarm or access control systems. It may be used to control devices of high power consumption via OC outputs of alarm systems. Moreover, it ensures galvanic isolation of signals, power sources relating to the outputs of the module.

2. Module description.

2.1 Description of components and connectors of the PSU.

Element no. [fig. 1]	Opis
[1]	+IN- module's power input
[2]	Relay contacts: COM – common relay clamp NO - normally open relay clamp NC - normally closed relay clamp
[3]	LED optical indication: L1 (red ON): COM contacts, closed NO, OFF: COM contacts, closed NC.

3. Specifications

Voltage of the relay's coil	12V (10V DC÷14V DC)
Power consumption	25 mA max.
Number of relays	1
Voltage of the relay's contacts	30V DC / 50V AC max.
Current of the relay's contacts	1A max.
Operating conditions	II environmental class -10°C÷ 50°C
Dimensions	L=40, W=43, H=20 [mm, +/-2]
Net/gross weight	0,02 / 0,04 [kg]
Installation	Installation tape or installation bolt x2
Declarations, warranty	CE, 2 year from the production date
Notes	leads on connections: Ø 0,41÷1,63 (AWG 26-14), 0,2÷1mm ²

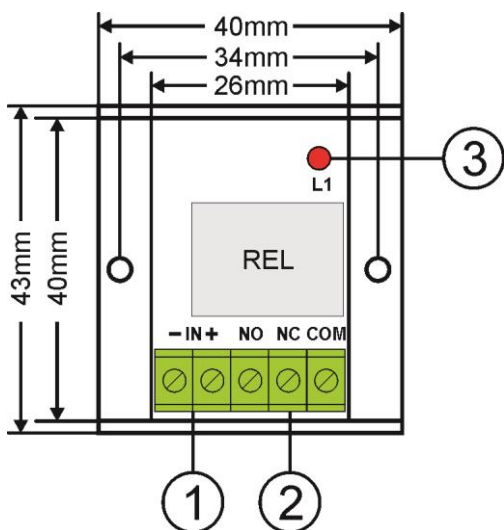

Fig.1. Drawing of the module.

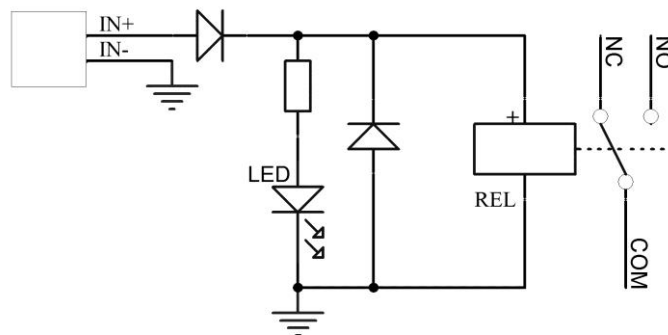

Fig.2. Electrical diagram.

WEEE MARKING

According to the EU WEE Directive – It is required not to dispose of electric or electronic waste as unsorted municipal waste and to collect such WEEE separately.

Pulsar

Siedlec 150, 32-744 Łapczyca, Polska
Tel. (+48) 14-610-19-40, Fax. (+48) 14-610-19-50
e-mail: biuro@pulsar.pl, sales@pulsar.pl
http:// www.pulsar.pl, www.zasilacze.pl